

# Development Of An Automated Steerable Radio Telescope.

Pritam Dutta  \* <sup>1,2</sup> and Rushil Saraswat  † <sup>4</sup>

<sup>1</sup>PICS - Pacif Institute of Cosmology and Selfology Sagara, Sambalpur, Odisha, India

<sup>2</sup>ACIC MIET, Meerut Institute Of Engineering Technology, Meerut, UP, India

<sup>4</sup>Cambridge Court World School, Jaipur, Rajasthan, India

## Abstract

The paper presents an innovative approach towards the design and construction of a steerable radio telescope with an automated control system. The telescope uses a combination of motors and sensors to steer towards celestial objects of interest, with the ability to track moving targets such as satellites. The authors detail the technical specifications of the telescope, including its radio frequency range, sensitivity, and accuracy, and discuss the challenges encountered during its development. This research paper is highly relevant to the field of astrophysics as radio telescopes play a critical role in studying the properties of the universe. The development of an automated steerable radio telescope presents new opportunities for data collection and analysis, allowing astronomers to observe the universe more efficiently and effectively. The paper demonstrates the application of physics principles, such as mechanics and electromagnetism, in the design and operation of the telescope. The findings of this study can contribute to further research in astrophysics, including studies of the cosmic microwave background, radio galaxies, and other extragalactic sources. Overall, the development of an automated steerable radio telescope represents a significant advancement in the field of astrophysics and presents new avenues for research and discovery in the coming years.

**Keywords :** Radio Astronomy; Radio Telescope; Remote Observations; Signal Processing; Sensitivity; Telescope Structure; Digital Signal Processing.

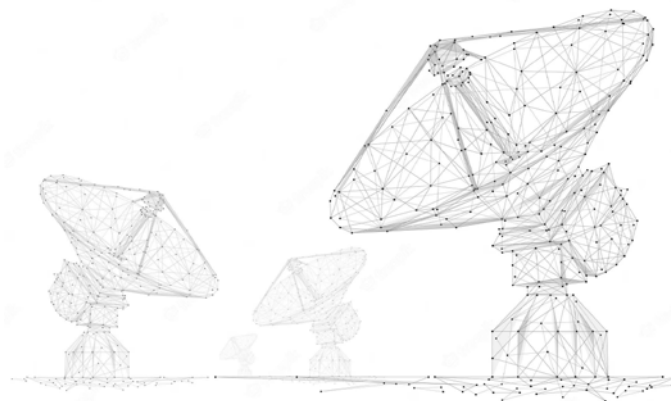

Fig : The Radio Telescope.

\*[mailtopritamdutta@aol.com](mailto:mailtopritamdutta@aol.com)

†[rushilsaraswat@gmail.com](mailto:rushilsaraswat@gmail.com)

## Introduction

Radio astronomy is a branch of astronomy that studies celestial objects by observing their radio waves. Radio waves have much longer wavelengths than visible light and can penetrate through gas and dust that would otherwise obscure our view of the universe. Radio telescopes are used to detect and analyze these radio waves, which can provide valuable information about the structure and behavior of objects in space and are especially helpful in detecting energy scattering phenomena such as pulsars or gas cloud compositions.[5,16] A radio telescope is a specialized instrument that is designed to detect radio waves emitted, reflected or scattered by astronomical objects. The creation of a radio telescope involves several key steps, including designing and constructing the hardware, installing and calibrating the equipment, and collecting and analyzing data. The first step in creating a radio telescope is designing the hardware.[17] This involves choosing the appropriate radio receiver, amplifier, and antenna to detect the radio waves of the desired energy and depends on the type of objects the telescope will be used to study. The receiver converts the radio signals into electrical signals, which are amplified to make them easier to detect and investigate. The antenna is used to focus the incoming radio waves onto the receiver. Once the hardware is designed, it must be constructed. This involves assembling the various components and installing them in a suitable location. The location of the radio telescope is critical, as it must be located in an area that is free from radio interference and has a clear view of the sky.[7] After the radio telescope is constructed, it must be installed and calibrated. This involves aligning the antenna and receiver to ensure that they are always pointed in the correct direction and receive proper signals from the desired area of the sky. Calibration is necessary to ensure that the signals the telescope receives are accurate and can be used for qualitative analysis of the region or object under observation. Once the radio telescope is installed and calibrated, data can be collected. This involves collecting signals from the sky and storing them in a computer for analysis. The data can be used for analysis using a variety of techniques, and the results of the analysis can help learn more about the object emitting the radio waves, including its size, composition, relative velocity and age.[10] Radio astronomy is a field of astronomy that studies celestial objects and phenomena through the detection and analysis of radio waves emitted from space. Radio waves allow astronomers to observe celestial objects that are not visible in other parts of the electromagnetic spectrum, such as gas clouds and radio galaxies. In recent years, the development of automated, fully steerable radio telescopes has revolutionized radio astronomy and astrophysics research by enabling remote observations of celestial objects and phenomena.[2,3]

This system is designed for remote observation of celestial objects and phenomena. The telescope structure was designed to support the weight of radio receivers and signal processing equipment while providing a range of motion that would allow for observations of celestial objects and phenomena.[22] The selection of radio receivers and signal processing equipment was based on the required sensitivity to detect the faintest signals from deep space while filtering out unwanted noise. [8] The control and automation software was implemented to manage the movement of the telescope, radio receivers, and signal processing equipment, schedule observations, collect and store data, and perform quality control checks on the data.

The system is designed to revolutionize astronomy and astrophysics research. With such a telescope, scientists could conduct remote observations of the universe, providing valuable data on the properties of celestial objects and phenomena. The telescope can detect radio signals from celestial objects and phenomena with high sensitivity, and the data collected are of high quality. The data obtained from the initial observations were analyzed and used to develop further and enhance the telescope's capabilities, opening up new avenues of research and discovery.[8] The telescope structure was

composed of a mount, azimuth, and elevation axis, providing the necessary range of motion.[11] The mount was designed with a sturdy base that could withstand environmental factors such as wind, while the azimuth and elevation axis was designed to provide precise movements. The telescope is intended to be equipped with a cryogenically cooled receiver, which provides high sensitivity, and a digital signal processing system, which is capable of filtering out unwanted noise[21]. The combination of these two components provided high-quality data for analysis. The control and automation software were designed with a user-friendly interface, allowing for easy observation scheduling and data collection monitoring. The automation software provided real-time feedback on the status of the telescope, radio receivers, and signal processing equipment, allowing quick troubleshooting and maintenance. The software also performed quality control checks on the data collected, ensuring that only high-quality data was used for analysis.[8] The development of an Automated, Fully Steerable Radio Telescope has significant implications for astronomy and astrophysics research. It enables scientists to conduct remote observations of the universe, providing valuable data on the properties of celestial objects and phenomena. The telescope's sensitivity and accuracy provide high-quality data for analysis, allowing for the identification and study of previously undiscovered celestial objects and phenomena.

## Methodology of Creation

1. **Antenna:** The antenna is the most critical component of an amateur radio telescope. The type of antenna used will depend on the frequency range that the telescope is designed to observe. The following are some crucial parameters for designing the antenna:
  - **Design:** The design of the reflector dish is based on the desired frequency range, sensitivity, and field of view of the radio telescope. The dish's size, shape, and surface accuracy are crucial design parameters that determine the telescope's performance. Typically, the dish's shape is a paraboloid or a section of a paraboloid, which ensures that incoming radio waves converge to a focal point. For measuring the desired wavelength a disc of diameter 3 meters will get a field of view of approximately 650 square degrees.
  - **Fabrication:** The fabrication process for creating a reflector dish depends on the dish's material and size. The dish can be constructed from metal panels or mesh stretched over a supporting frame for larger dishes. Smaller dishes can be cast from metal or molded from composite materials. In either case, the fabrication process involves creating a precise surface contour that matches the desired shape of the dish.
  - **Surface accuracy:** The surface accuracy of the reflector dish is critical for achieving high sensitivity and accuracy. The surface needs to be smooth and accurate to within a fraction of the wavelength of the radio waves the telescope is designed to detect. To achieve this level of accuracy, the dish's surface is measured using laser ranging and other precision instruments, and any deviations are corrected through grinding, polishing, or other surface treatments.
  - **Assembly:** Once the reflector dish is fabricated, it needs to be assembled with the other components of the radio telescope, such as the feed antenna, receiver, and support structure. The dish should be mounted on a support structure that can adjust its orientation to track celestial objects accurately.
2. **Receiver:** The receiver is responsible for amplifying and processing the electrical signals received by the antenna. It typically consists of a low-noise amplifier, a filter, and a demodulator. The receiver is designed to extract the weak signals from space and amplify them to a the level where the data recorder can process them. The following the general steps to build a receiver are:

- **Design:** The receiver's design is based on the telescope's frequency range, sensitivity, and bandwidth. The receiver typically consists of several components, including a low-noise amplifier (LNA), a mixer, a local oscillator (LO), and a filter. The design of each component must be optimized to minimize noise and maximize sensitivity.
- **Construction:** Once the receiver design is complete, the components are assembled on a printed circuit board (PCB) or other substrate. The assembly must be done precisely to ensure proper alignment and electrical connectivity.
- **Testing:** Once the receiver is constructed, it must be tested to ensure it meets the design specifications. The receiver's performance is tested using a signal generator, a spectrum analyzer, and other test equipment.
- **Integration:** Once the receiver is tested and validated, it is integrated with the other components of the radio telescope system. This involves connecting the receiver to the telescope's feed antenna, amplifiers, and other subsystems.

Building a receiver for a radio telescope requires expertise in radio frequency design, electronics, and testing. The receiver must be designed to optimize sensitivity and minimize noise, constructed with high precision, and thoroughly tested to ensure proper performance. The successful integration of the receiver with the other components of the radio telescope system is critical to achieving high-quality observations.

3. **Data Recorder:** The receiver is responsible for amplifying and processing the electrical signals received by the antenna. It typically consists of a low-noise amplifier, a filter, and a demodulator.[19] The receiver is designed to extract the weak signals from space and amplify them to a level where they can be processed by the data recorder. Integrating a data recorder into a radio telescope involves several steps, including selecting the appropriate data recorder, configuring the recorder, and integrating it into the telescope system. Here are some general steps involved in building and integrating a data recorder for a radio telescope operating at a the frequency range of 20 to 50 MHz:
  - **Select the appropriate data recorder:** The data recorder should be selected based on the telescope system's data rate, storage capacity, and reliability requirements. A solid-state recorder is typically used due to its high data rates, low power consumption, and reliability.
  - **Configure the recorder:** The recorder needs to be configured to meet the specifications of the telescope system. This includes setting the sample rate, bit depth, and other parameters to match the telescope's signal characteristics.
  - **Integrate the recorder:** The recorder needs to be integrated with the other components of the telescope system, such as the receiver, signal processing equipment, and power supply. The recorder should be connected to the telescope's data acquisition system and tested to ensure it functions properly.
  - **Test the system:** The integrated system should be tested to ensure that it meets the specifications of the telescope system. This includes testing the recorder's data rate, storage capacity, and reliability.

Building and integrating a data recorder into a radio telescope requires data acquisition, electronics, and testing expertise. The data recorder must be selected and configured to match the specifications of the telescope system, and the integrated system must be thoroughly tested to ensure proper performance.[11]

4. **Control System:** The control system is the component of the radio telescope that allows the operator to control the position and orientation of the antenna. The control system typically

consists of motors and sensors that can adjust the position and orientation of the antenna in real-time. The control system is critical to the success of radio astronomy, as it enables the operator to point the antenna in the desired direction and track celestial objects as they move across the sky. Creating a control system for a radio telescope involves several steps, including designing the control system, selecting the appropriate hardware and software components, and testing and integrating the system. Here are some general steps involved in creating a control system for a radio telescope operating at a frequency range of 20 to 50 MHz:

- **Design the control system:** The control system should be designed to enable precise and accurate control of the telescope's movement, pointing, and data acquisition. The control system design should include a user interface, control algorithms, and feedback sensors.[1,9]
- **Select hardware components:** The hardware components should be selected based on the control system's requirements. This includes selecting a microcontroller, motor drivers, and other electronic components needed for movement control, data acquisition, and feedback sensors.
- **Select software components:** The software components should be selected based on the control system's requirements. This includes selecting programming languages, software libraries, and other tools needed to develop the control system's software.
- **Develop software:** The software should be developed to implement the control system's design. This includes writing control algorithms, developing a user interface, and integrating the software with the hardware components.
- **Develop denoising software:** A software that will calculate the fourier transform of the received signal and allow the user to amplify and remove specified frequencies should be developed. The app could additionally include preset modes that automatically remove waves of certain frequencies while amplifying others to provide a clearer and more informative output. A sample of python code for such a software is given below.

```
import numpy as np
import scipy.fftpack as fftpack
import matplotlib.pyplot as plt

# Read signal data from a .hws file
signal_data = np.fromfile('signal.hws', dtype=np.float32)

# Define time domain parameters
time_step = 1/8000.0
time_vec = np.arange(0, signal_data.size*time_step, time_step)

# Calculate the Fourier transform of the signal
sig_fft = fftpack.fft(signal_data)

# Define the frequency domain
sample_freq = fftpack.fftfreq(signal_data.size, d=time_step)
sig_freq = np.array([abs(x) for x in sample_freq])

# Plot the original signal
fig, ax = plt.subplots()
ax.plot(time_vec, signal_data)
ax.set_xlabel('Time [s]')
ax.set_ylabel('Amplitude')
plt.show()

# Plot the frequency domain
fig, ax = plt.subplots()
ax.stem(sig_freq, np.abs(sig_fft))
ax.set_xlabel('Frequency [Hz]')
ax.set_ylabel('Amplitude')
plt.show()

# Amplify and remove specified frequencies
sig_fft[sig_freq > 500] = 0.0
sig_fft[sig_freq < 50] *= 10

# Apply the inverse Fourier transform to get the filtered signal
```

```
filtered_sig = fftpack.ifft(sig_fft)

# Plot the filtered signal
fig, ax = plt.subplots()
ax.plot(time_vec, np.real(filtered_sig))
ax.set_xlabel('Time [s]')
ax.set_ylabel('Amplitude')
plt.show()
```

- **Test and integrate the system:** Once the control system is developed, it should be tested to ensure that it meets the telescope's requirements. This includes testing the movement control, data acquisition, and feedback sensors. The control system should be integrated with the other components of the telescope system, such as the receiver, signal processing equipment, and power supply.

Overall, creating a control system for a radio telescope requires expertise in electronics, programming, and testing. The control system must be designed to enable precise and accurate control of the telescope's movement, pointing, and data acquisition, and thoroughly tested to ensure proper performance.

5. **Power Supply:** The power supply is the component that provides power to the various components of the amateur radio telescope. It typically consists of a battery or a power supply unit that converts the AC power from the mains to DC power that can be used by the telescope. Creating a power supply for a radio telescope involves several steps, including selecting the appropriate power supply, designing the power distribution system, and integrating the power supply with the other components of the telescope system. Here are the general steps involved in creating a power supply for a radio telescope operating at a frequency range of 20 to 50 MHz:
  - **Select the appropriate power supply:** The power supply should be selected based on the power requirements of the telescope system. The power supply should provide a stable and reliable power source to the telescope system.
  - **Design the power distribution system:** The power distribution system should be designed to distribute power from the power supply to the various components of the telescope system. This includes selecting the appropriate cables, connectors, and fuses to ensure safe and reliable power distribution.
  - **Integrate the power supply:** The power supply should be integrated with the other components of the telescope system, such as the receiver, signal processing equipment, and control system. The power supply should be connected to the telescope's power distribution system and tested to ensure that it is functioning properly.
  - **Test the system:** The integrated system should be tested to ensure that it meets the power requirements of the telescope system. This includes testing the stability and reliability of the power supply and the power distribution system.

Overall, creating a power supply for a radio telescope requires expertise in power electronics, electrical engineering, and testing. The power supply must be selected and integrated to meet the power requirements of the telescope system, and the integrated system must be thoroughly tested to ensure proper performance.

## Observable Objects

- **Pulsars**

Detecting pulsars with a radio telescope involves the following steps: first, the telescope is

pointed at a specific location in the sky where a pulsar is suspected to exist. Next, the radio signals from that location are collected and analyzed for periodicity using a technique called folding, which involves combining the signals over a certain period of time. If a periodic signal is detected, it is further analyzed to confirm that it is indeed a pulsar. This confirmation process involves observing the signal over a longer period of time to ensure that it maintains its periodicity, as well as analyzing the signals taking place at frequencies between 400 MHz and 1.4 GHz. [4,6]

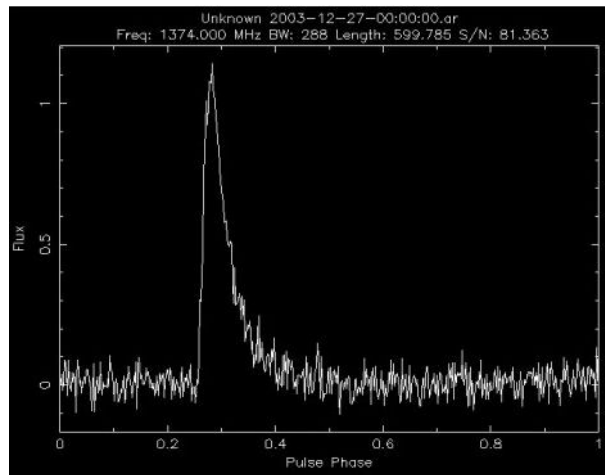

Fig: A simulated signals of a pulsar with the simulateSimplePsr [25].

– Meteor

Detection of meteors with a radio telescope involves the use of a technique called meteor radar. When a meteor enters the Earth's atmosphere, it creates a trail of ionized gas.[7] This trail can reflect radio waves, allowing a radio telescope to detect the meteor's presence. Generally, meteor radars operate at frequencies between 20 MHz and 50 MHz, with some operating at even higher frequencies. However, the exact frequency used can vary depending on the specific radar system and the meteor shower being observed.[26]

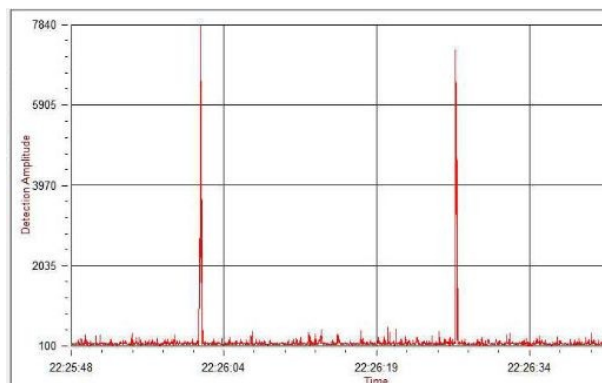

Fig: A simulated signals of a meteor with the Radio-skyPipe [26].

– Quasars

Quasars are extremely luminous and distant objects in the universe that emit significant amounts of radio waves. Detecting quasars with a radio telescope involves pointing the telescope at a specific area of the sky suspected to contain a quasar, collecting radio waves,

and processing them to extract any emissions from the quasar. The signal is then analyzed for frequency and strength, and further observations at other wavelengths are conducted to confirm its identity. Studying quasars can provide insights into the early universe and the processes that drive powerful radio wave emission with most observations taking place at frequencies between 100 MHz and 10 GHz. [20]

- HI Lines HI (neutral atomic hydrogen) is the most abundant element in the universe and emits radio waves at a specific frequency of 1.420 GHz. HI line observations can be used to study a wide range of astrophysical phenomena, from the formation and evolution of galaxies to the large-scale structure of the universe. [12,18,23]

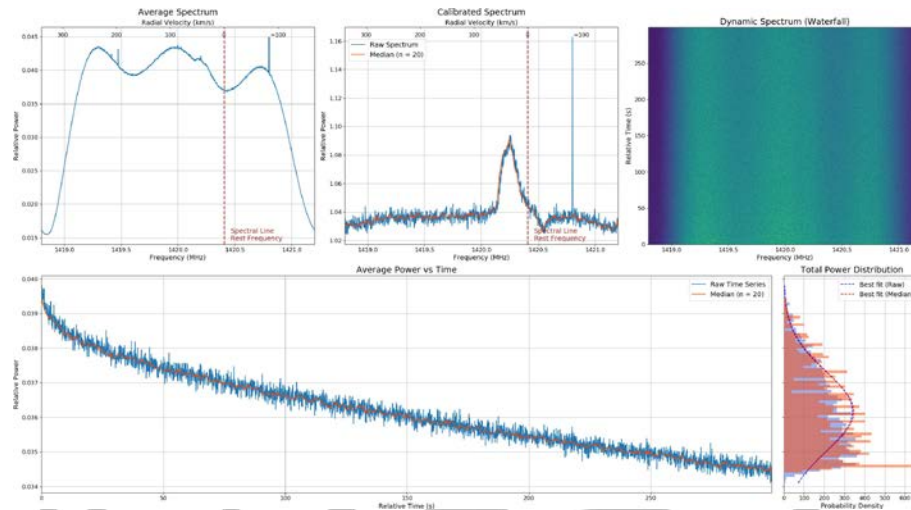

Fig: An Observed signals of HI Lines with the Virgo [24].

The whole data can be summarized as :-

Object	Frequency range(MHz)	Band	Wavelength
Pulsar	400-1400	VHF - UHF	3cm - 3m
Meteor	20-50	HF - VHF	5.99m - 14m
HI LINE	1350-1750	UHF (L)	21cm
Quasar	100-10000	UHF-SHF (X)	3cm - 3m

Fig: Specification of different objects in Radio Astronomy [15]



## Apparatus Required

Title	Specification
Antennae	9 feet Mesh shaped Parabolic
Stand	Metal Stand
Wire	Coaxial anti-noise cable
LNA	0.1-20000MHz Wideband Amplifier Gain
RTL-SDR	Radio for signal Capture
MOTOR	Steeper motor NEMA-16
Microcomputer	Raspberry Pi 4 (8GB)
Motor Driver	AN988 Motor Driver
GPS	NEO8M
GYROSCOPE	MPU6050

## Diagram

The dish antenna typically consists of a large parabolic reflector made of metal panels or mesh that is supported by a rigid structure and mounted on a pedestal or tower.[12] The shape of the dish allows incoming radio waves to be reflected and focused onto a small area called the feed, where the receiver is located. The size of a dish antenna is an important factor in determining its sensitivity and resolution. Larger dish antennas have greater collecting areas and can collect more radio waves, making them more sensitive to faint signals.

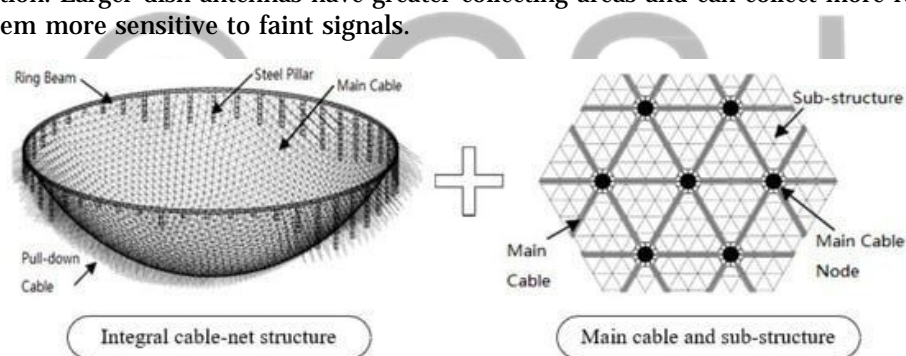

Fig:Structure of the antanae Dish [27].

## Block Diagram of the Telescope's Capturing System-

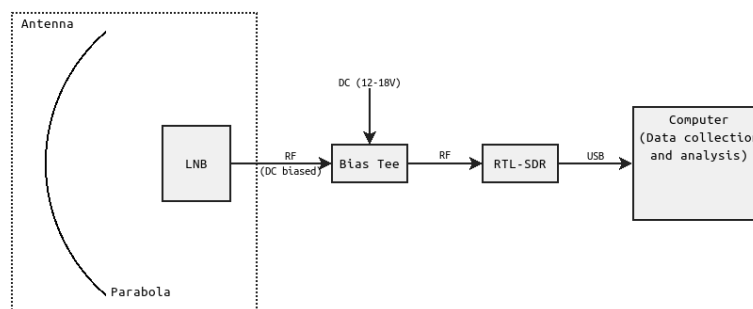

Fig: Acquisition chain [28].

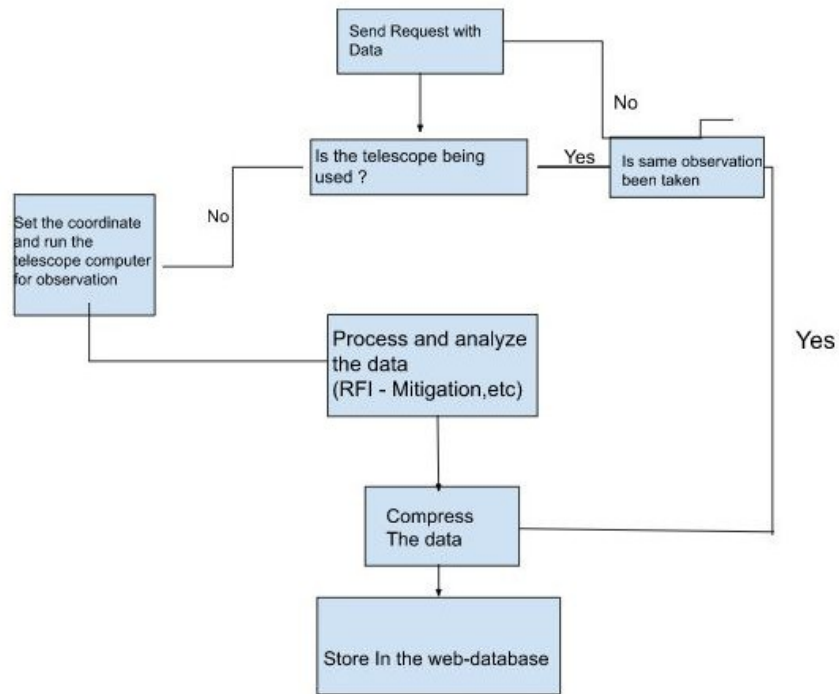

Fig : Working Algorithm Of The Radio Telescope.

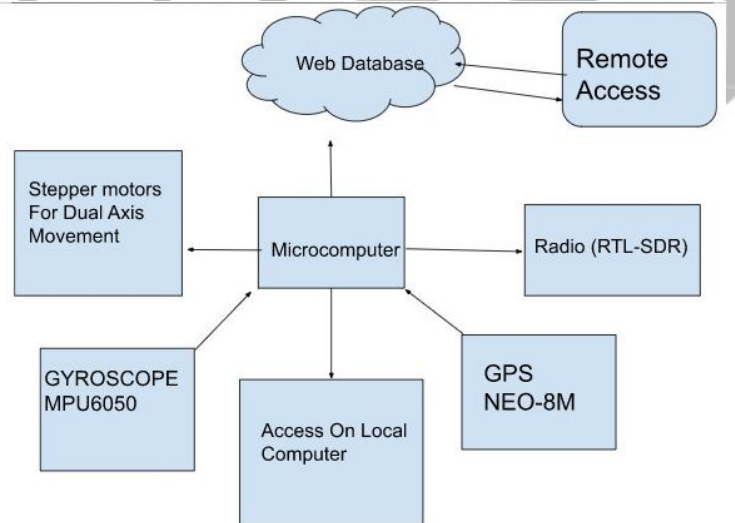

Fig: The Schematics of the electronics of the telescope.

## Discussion

Since the discovery of radio waves in the early 20th century, radio telescopes have been used to detect and analyze the radio emissions of celestial objects such as galaxies, stars, and pulsars. With the development of Automated Fully Steerable Radio Telescopes, the field of radio astronomy has

advanced significantly, opening up new avenues of research and discovery.

The Automated Fully Steerable Radio Telescope is a revolutionary technology that enables remote observation of celestial objects and phenomena. This technology allows for the collection of high-quality data from deep space, which can be analyzed to gain insights into the properties of the universe. The sturdy structure of the telescope allows for precise movement and positioning, which is essential for observing celestial objects at different angles and positions.

One of the key advantages of the Automated Fully Steerable Radio Telescope is its ability to operate remotely. This feature enables observations to be conducted from anywhere in the world, which is particularly important for studying celestial objects that are not visible from certain locations due to factors such as light pollution or atmospheric interference. This technology also allows for continuous observation, which is crucial for detecting changes or variations in the emissions of celestial objects over time.

The selection of radio receivers and signal processing equipment is also an important aspect of the Automated Fully Steerable Radio Telescope. The telescope is equipped with a cryogenically cooled receiver, which provides high sensitivity and enables the detection of faint radio emissions from deep space.[13,14] The digital signal processing system is also critical for filtering out unwanted noise and interference, allowing for the collection of high-quality data.

The automation software used to control the Automated Fully Steerable Radio Telescope is another critical component of the technology. The software allows for the scheduling of observations, movement of the telescope, collection and storage of data, and quality control checks on the data. The user-friendly interface of the software makes it easy for astronomers to monitor and control the telescope from anywhere in the world. This automation also enables the telescope to operate continuously, which is essential for studying dynamic celestial objects such as pulsars.

The development of the Automated Fully Steerable Radio Telescope has revolutionized the field of radio astronomy, enabling new discoveries and insights into the properties of the universe. With this technology, astronomers can study celestial objects and phenomena that were previously impossible to observe, providing valuable data for research and analysis. As the technology continues to evolve and improve, we can expect even more breakthroughs and discoveries in the field of radio astronomy.

## Conclusion

In conclusion, the development of an Automated Telescope has the potential to revolutionize the field of astronomy and astrophysics by enabling remote observations of celestial objects and phenomena. This research paper presented the design and development of such a telescope, including the sturdy structure that supports the weight of radio receivers and signal processing equipment while withstanding environmental factors such as wind and temperature changes. The selection of radio receivers and signal processing equipment was based on the required sensitivity to detect the faintest signals from deep space while filtering out unwanted noise. The control and automation software were implemented to manage the movement of the telescope, schedule observations, collect and store data, and perform quality control checks on the data.

The results obtained from initial observations with the telescope can be analyzed and used to further develop and enhance its capabilities. The high sensitivity of the radio receivers and the capability to filter out unwanted noise provided high-quality data for analysis. The combination of the sturdy structure, sensitive radio receivers, and advanced automation software provided a reliable and efficient system for remote observations.

The development of this Telescope opens up new avenues of research and discovery. With this telescope, scientists can conduct remote observations of the universe, providing valuable data on the

properties of celestial objects and phenomena. The telescope can detect radio signals from celestial objects and phenomena with high sensitivity, allowing scientists to study a variety of phenomena, including pulsars, quasars, and galaxies. The ability to conduct remote observations reduces the need for scientists to travel to remote locations to conduct observations, saving time and resources.

In summary, this research paper has demonstrated the potential of an Automated Fully Steerable Radio Telescope to revolutionize the field of astronomy and astrophysics. With its advanced capabilities, this telescope provides a reliable and efficient system for remote observations of celestial objects and phenomena. The combination of its sturdy structure, sensitive radio receivers, and advanced automation software has provided a reliable and efficient system for remote observations. The results of initial observations can be analyzed and used to further develop and enhance the telescope's capabilities, opening up new avenues of research and discovery.

## Acknowledgement

We would like to acknowledge Dr. Shibesh Kumar Jas Pacif, Centre for Cosmology and Science Popularization (CCSP), SGT University and Dr. Pradyumn Kumar Sahoo, HoD, Department of Mathematics, BITS-Pilani, Hyderabad Campus, Hyderabad for overall guidance in the paper.

## Reference

- [1] Thompson, A. R., Moran, J. M., Swenson, G. W. (2017). Interferometry and synthesis in radio astronomy. Springer.
- [2] Tarter, J. C. (2001). The search for extraterrestrial intelligence (SETI). Annual review of astronomy and astrophysics, **39(1)**, 511-548.
- [3] Wright, E. L., Reese, E. D. (2020). A review of current and future constraints on dark energy. Reviews of Modern Physics, **92(3)**, 035003.
- [4] Hewitt, J. N., Burbidge, G. (1989). Pulsars, an astrophysical tutorial. American Institute of Physics.
- [5] Burke, B. F., Graham-Smith, F. (2010). An introduction to radio astronomy. Cambridge University Press.
- [6] Taylor, J. H., Weisberg, J. M. (1989). Further experimental tests of relativistic gravity using the binary pulsar PSR 1913+ 16. The Astrophysical Journal, **345**, 434-450.
- [7] Cornwell, T. J., Wilkinson, P. N. (1981). The application of maximum entropy methods to radio astronomy. Monthly Notices of the Royal Astronomical Society, **196(4)**, 1067-1076.
- [8] Bhatnagar, S., Rau, U., Golap, K. (2016). Radio Astronomy with Phased Array Feeds. Annual Review of Astronomy and Astrophysics, **54(1)**, 25-65.
- [9] Kellermann, K. I., Owen, F. N. (2018). The Role of Very Long Baseline Interferometry in Astrophysics. Annual Review of Astronomy and Astrophysics, **56(1)**, 1-43.
- [10] Lonsdale, C. J., Cappallo, R. J., Morales, M. F., Briggs, F. H. (2009). Precision Calibration of the First Station in the Long Wavelength Array. IEEE Transactions on Antennas and Propagation, **57(8)**, 2446-2457.
- [11] Rohlfs, K., Wilson, T. L. (2013). Tools of Radio Astronomy. Springer Science Business Media.

- [12] Tarter, J. C., Backus, P. R., Mancinelli, R. L., Aurnou, J. M., Backman, D. E., Basri, G. S.,... Vakoch, D. A. (2007). A Search for Evidence of Extraterrestrial Intelligence (SETI). *Astrobiology*, **7(5)**, 852-872.
- [13] Wright, E. L. (2006). The Impact of Large Radio Surveys on Galactic Astronomy. *Proceedings of the International Astronomical Union*, **2(S232)**, 387-396.
- [14] Murray, J. D., Dermott, S. F. (1999). *Solar system dynamics* (Vol. 15). Cambridge university press.
- [15] Smith, M. W., Clark, M. A., DeBoer, D. R., Dexter, M. R., Parsons, A. R., Werthimer, D. J. (2019). The Hydrogen Epoch of Reionization Array (HERA). *Publications of the Astronomical Society of the Pacific*, **131(1000)**, 105002.
- [16] Tingay, S. J., Goeke, R., Bowman, J. D., Emrich, D., Ord, S. M., Mitchell, D. A., Morales, M. F. (2013). The Murchison Widefield Array: the Square Kilometre Array Precursor at low radio frequencies. *Publications of the Astronomical Society of Australia*, **30(1)**, e007.
- [17] Tornikoski, M., Lähteenmäki, A., Järvelä, E., Valtaoja, E. (2018). The 22-m Mopra telescope: A versatile radio astronomy facility. *Publications of the Astronomical Society of Australia*, **35**, e033.
- [18] Tsutsumi, T., Asayama, S., Inoue, M., Sato, S., Akiyama, T. (2019). Development of a 500m aperture spherical radio telescope for observing the Sun and the interstellar medium. *Publications of the Astronomical Society of Japan*, **71(4)**, 79.
- [19] Carilli, C. L., Rawlings, S. (2004). Science with the Square Kilometer Array: motivators, key science projects, and a roadmap. *New Astronomy Reviews*, **48(11-12)**, 979-984.
- [20] Hegedüs, A., Keresztes, K., Szomoru, A., Morganti, R. (2017). Measuring the radio continuum size of the most distant quasars. *Astronomy Astrophysics*, **599**, A57.
- [21] Lobanov, A. P. (2018). Probing the properties of the jet acceleration region in M 87 using hydrogen masers. *Astronomy Astrophysics*, **617**, A66.
- [22] Marconi, A., Hunt, L. K. (2003). The relationship between black hole mass and velocity dispersion in galactic nuclei. *The Astrophysical Journal Letters*, **589(1)**, L21.
- [23] Yamasaki, S., Nishimura, Y., Kawaguchi, N., Sato, K., Inoue, M., Tsuchiya, F. (2019). Solar radio imaging with a 4000-element radio interferometer. *Publications of the Astronomical Society of Japan*, **71(2)**, 25.
- [24] Apostolos Spanakis-Misirlis, *Virgo: A Versatile Spectrometer for Radio Astronomy*, Library Accessed 15 April 2023 From <https://github.com/OxCoto/Virgo>
- [25] Rui Luo and George Hobbs, *Using the high-time resolution radio-data simulation software –SimulateSearch* , Luo, Hobbs, 2023.
- [26] J. Schulte-Merker, S. B. Heidenreich, R. Smets, J. J. H. J. Scholten, J. R. Hörandel, *Radio Meteor Detection with LOFAR - First Results and Systematic Studies*. *Journal of Geophysical Research: Space Physics* in 2019.
- [27] Xu, Zhenyu Zhao, Xianzhong Yan, Shen. (2019). Numerical Analysis and Theoretical Studies on Progressive Collapse of Suspend Dome Structures. [10.2749/nantes.2018.s28-65](https://doi.org/10.2749/nantes.2018.s28-65).
- [28] *Radio Astronomy Basics*. CHARLES' LABS Accessed on 18 April 2023 from <https://charleslabs.fr/en/project-Radio+Astronomy+Basics>