

GSJ: Volume 14, Issue 3, March 2026, Online: ISSN 2320-9186

www.globalscientificjournal.com

**AC-BaC: Effectiveness of Utilizing Activated Carbon Moso Bamboo Charcoal
with an Innovative Vacuum Device to Reduce Foul Odors in Confined Spaces**



An Official Entry to the
Division Science and Technology Fair 2025



Christine Joy Gildore
Proponent

Engineer Victor Ianito Puzon
Qualified Scientist (**Professional Civil Engineer**)

Arlene C. Somollo
Research Adviser

October 2025

TABLE OF CONTENTS

	Page
ABSTRACT	3
INTRODUCTION	4
REVIEW OF RELATED LITERATURE	6
INVENTION FRAMEWORK	9
MATERIALS AND METHODS	11
RESULTS	20
DISCUSSION	22
BENEFITS	24
CONCLUSION	25
ACKNOWLEDGEMENTS	26
FUTURE DEVELOPMENT	26
REFERENCES/ BIBLIOGRAPHY	27

ABSTRACT

The goal and objective of the study focuses on developing an eco-friendly air purification system designed to reduce foul odors and harmful air pollutants in confined spaces and promote public health. The research utilized activated carbon derived from Moso bamboo charcoal, a renewable resource known for its high porosity and adsorption capacity, as the primary filtering medium within a portable vacuum-based device. Focusing in contributing to the environment, community, the health and safety medical respiratory purposes for individuals.

Component and features include 2 DC Fan Blowers that acts as the input and output airflow of the vacuum, a small DC Switch for on and off activation, 12V Battery and lastly is the main filtering medium, the natural activated bamboo charcoal, not making use of any chemicals in the process of activation. Its function being the one who purifies or filters indoor air without relying on chemical-based air fresheners, promoting sustainability and environmental safety.

This research highlights the importance of maintaining clean indoor air quality, the significance of this study lies in its potential to protect and save individuals exposed to poor air quality, which directly contributes to the safety and comfort of individuals, especially those with asthmatic or respiratory conditions and illnesses. By providing a sustainable and low-cost air purification solution, the study aims to minimize exposure to pollutants that may trigger asthma attacks or other breathing difficulties, promoting a healthier and safer living environment, and also contributing to achieve cleaner air and reducing air pollution.

Keywords: Activated Bamboo Charcoal, Air Purifier, Filter, Adsorption Capacity, Eco-friendly Innovation, Healthy and Safety for Individuals, Air Quality, Odor Reduction, Sustainable Technology, Vacuum Device

INTRODUCTION

Background of the Study

Developed and created AC-BaC, a small pack vacuum device that contains Activated Bamboo Charcoal inside which came from Natural Bamboo Charcoal processed into granules for its micropores that captures and encapsulates the vacuumed or sucked in bad odor molecules and filters them out. In addition to removing odors, activated charcoal also decreases the necessity for use of chemical air fresheners, which benefits users health and safety.

Unpleasant odors are frequently found in bathrooms, especially public restrooms, and other smaller areas. Modern air fresheners usually just mask odors with artificial- chemical use fragrances rather than getting rid of them. According to Environmental Protection Agency (EPA) studies on human exposure to air pollutants (Wang, Zhang, 2011) Indoor air quality (IAQ) is still a major concern since it has a big impact on people's productivity, comfort, health, and happiness and that indoor air levels of many pollutants can be two to five times, and sometimes more than 100 times, higher than outside levels, So this odor-elimination way makes activated bamboo charcoal a popular choice for both industrial and household applications.

This study aims to enhance home and public restrooms by providing an affordable, environmentally friendly air purification choice. The project integrates local application as it includes testing in confined spaces such as in community like household bathrooms or in the school of City High women and men restrooms, also with the national initiative and idea of using bamboo charcoal for sustainable technology, aligning with Department of Science and Technology (DOST) - Forest Products Research and Development Institute (FPRDI) Bamboo ACTIVE Ph program for generating and creating a solution in reducing foul odors and air pollution for the benefit of human health. The project is likely to be well-accepted due to its:

- Eco-friendly materials (bamboo is sustainable and biodegradable),
- Low cost and DIY-friendly construction,
- Health-conscious design, avoiding chemical-based air fresheners,

It promotes both environmental awareness and practical benefits, making it suitable for local communities and even commercial use.

Activated carbon is used for air quality control, gas purification, solvent recovery, and the elimination of hazardous materials from industrial emissions are all applications for activated carbon (Hanies Ambarsari et al., 2016). Due to its high efficiency, simple use, and affordability, adsorption with activated carbon (AC) is one of the most popular odor treatment techniques (Bunmahotama et al., 2017; Tennant & Mazyck, 2007; Pendleton et al., 1997).

Problem Statement

This project aimed to assemble a portable vacuum device that uses activated bamboo charcoal as the main filtering mechanism. Specifically, the researcher intends to answer the following questions:

1. What is the adsorption capacity of Activated Bamboo Charcoal in adsorbing foul odors?
2. Does the efficiency of reducing foul odors can be rated based on the following?:
 - a.) By doing Surveys or Interview logs from participant's own experience and observation of the AC-BaC's performance level.
 - b.) Quantitative numerical collected data from the readings of Air Quality Meter Sensor and tools.
2. Is there a significant difference between using Activated Bamboo Charcoal and store-bought Air Fresheners in reducing foul odors in confined areas?

Features and Specifications

The AC-BaC (Activated Carbon- Bamboo Charcoal) device, is simply a custom made vacuum that has an input and output airway where the bad odors would be sucked in and exit out as filtered air, it is powered by a 12 V battery, has a one switch power button so it is not complicated to use and handle for users. Also the activated bamboo charcoal can be easily replaced and refilled when needed, has a custom container inside that is removable and efficient to manage for maintenance. Makes use of activated bamboo charcoal/carbon as the main filtering system for reducing or eliminating foul odors, does not make use of any chemical ingredients so it is environment and user friendly.

Market Trends and Opportunities

This project aims to develop an eco-friendly foul odor eliminating device, that doesn't cover up or just masks the smell but instead adsorbs it, making it more efficient to use rather than air fresheners that uses chemicals to only masks the odor instead of filtering it. Given its affordability and sustainability, the device gives off a potential for real-world application and future marketing adaptation in indoor air purification.

So instead of regular store- bought air purifiers that already exists, not only that it consumes a lot of power, energy and electricity to use but some are expensive and costly to obtain for regular users. Unlike the AC-BaC device, that has a natural filtering system with the use of activated bamboo charcoal and only uses 12V battery that can last for a long time, and can easily be refilled and replaced if needed to for maintenance.

Researchers Spokas, Hagemann, Schmidt, and others (2018) highlighted that, Activated carbon is a common, relatively inexpensive adsorbent frequently utilized in the pharmaceutical industry, activated carbon is being used more and more for odor control and other environmental applications. The study talks about activated bamboo

carbon's adsorption properties and confirms that it works well to get rid of unpleasant odors, especially in waste management and improving indoor air quality, finding more sources into proving that bamboo charcoal is still a high main choice especially for household and industrial use.

Researches by Chien et al. (2011) stated that a less costly activated carbon with the same or even better adsorptive capability as the imported adsorbent can be made from bamboo, compared other adsorbents, activated carbon-based adsorbents are cheaper, easier to obtain, better adsorption performance and easier to operate due to its wide use in catalyst carriers, purification of toxic gases, so it is a wide choice for households and enclosed areas to handle lingering odor with its properties of being a beneficial and affordable way.

REVIEW OF RELATED LITERATURE

Activated Bamboo Charcoal

A compact, portable vacuum device that uses activated bamboo charcoal to get rid of odors, which acts as the main independent variable. Activated Bamboo Charcoal is the most adaptable adsorption material due to its various physical and chemical properties, including its large surface area with porous structure, good adsorption capacity, and modified surface chemical structure (Isa et al., 2016). Other bamboo sources can still be utilized but it is highly recommended to make use of *Phyllostachys edulis*, commonly known as Moso bamboo. This specific type of bamboo has been widely studied and favored for high-quality activated carbon production due to its:

- Excellent carbon content and rapid growth rate
- Proven high adsorption performance for VOCs and harmful gases at carbonization temperatures from 500 °C to 1000 °C, with improved effectiveness at higher temperatures (Samarawickrama et al., 2020).
- Ability to generate activated bamboo carbon with a very high specific surface area (up to 2237 m²/g) and over 1.2 cm³/g total pore volume when chemically activated (Manoratne et al., 2020)

Moso outperforms all other bamboos and hardwood varieties in carbon dioxide absorption and oxygen production. Since it is a microscopic "sponge" structure, atoms or molecules can stick to its surface during adsorption, which is used to capture or remove specific compounds, its large surface area and porous structure increases the surface area available for adsorption. All things considered, other bamboo types can still be used but Moso Bamboo results and provides best quality odor adsorption process, it has been shown to be successful in adsorbing gases and volatile organic compounds (VOCs) that produce foul smells, such as ammonia and chemicals based on sulfur (Gelles et al., 2020). While the dependent variable would be the basis if the results of the study is successful, impactful or not.

So in all terms, it's a more better choice, including its large and wide porous surface area influencing its high conductivity and adsorb ability. Considering that the aim of this study is creating a natural air purifier, it is proven that bamboo charcoal can filter out Ammonia, Sulfur compounds, Formaldehyde, Airborne bacteria and allergens

(Le-Minh et al., 2018). Also, unlike using synthetic air fresheners that makes use of chemicals to only mask the smell, bamboo activated charcoal would reduce and filter foul odors in a natural way (Bagreev & Bandosz, 2001)

The "activating" process turns organic components with a lot of microscopic pores on the surface area, the charcoal's pores offer it a lot of surface area to trap toxins and other chemicals, according to Stuart and Wiginton (2024), this makes charcoal an excellent choice for air purification in places like bathrooms, basements, and other enclosed areas.

THEORETICAL FRAMEWORK

Charcoal already being an effective or proven way of filtering out air, but transforming and processing it into Activated Carbon will widen its scope of adsorbing odor molecules. In the process of making Activated Bamboo Carbon, it includes using citric acid or lemon solution as it is the one activating the wide adsorption capacity of any charcoal, Researcher Dąbrowski (2001) states "adsorption in micropores is basically a pore-filling process where the primary controlling factor is the size of the pore.", which proves that activated carbons has the ability to fill its pores with foul odor molecules due to its big factor, its pore size.

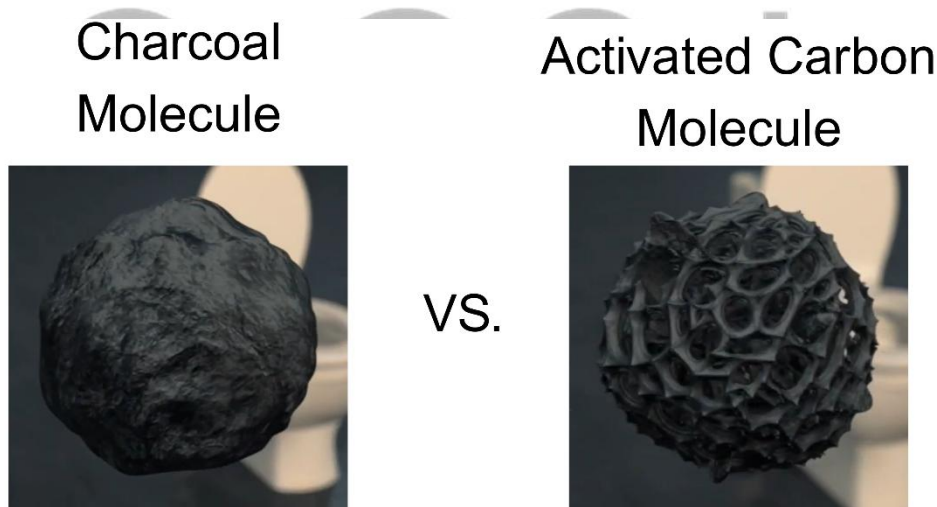

Figure 1: The microscopic porous surface area difference between Charcoal and Charcoal processed into Activated Carbon.

As seen in the picture, the natural surface area of a charcoal doesn't have much microscopic pores, while on the other hand, the processed activated bamboo carbon that has absorbed the citric acid and has undergo the process of activation, has a lot of porous surface area which leads to odor molecules to being adsorbed and entrapped inside, concluding its high adsorption efficacy.

This unique structure allows activated charcoal to effectively trap and remove impurities or pollutants from liquids and gases, has a wide range of uses, from air and water filtration to medical treatments and cosmetics. From the studies of Distilled Spirits (2023) Activated carbon is a low-cost material with distinguishable properties

like high specific surface area, high porosity, and desired surface functionalization, making it a wide accessible use for all and also its high efficacy rate.

High adsorption properties



Figure 2: Odor molecules attaching or being adsorbed by the microscopic porous surface area of the Activated Carbon.

The figure above clearly shows the microscopic foul odor particles being adsorbed by the porous surface area of the activated carbon, the porous surface area encapsulating and trapping the odor molecules, resulting to filtered out air. Study related to Alves et al. (2021) Activated carbon has the ability to selectively collect gases, liquids and impurities inside its pores, which is the reason it is widely used in filtration systems.

So overall, the high porous surface area of the Activated Carbon is the main reason for its adsorbing molecule properties. Bhave and Yeleswarap (2020) presented the study of adsorption being one of the most preferred air purification systems making Activated carbon a preferred option due to its high microporous volume and adsorption kinetics. To conclude, Charcoal processed into activated carbon for its microscopic pores to enlarge, and widen the capacity in adsorbing foul odor molecules.

The longevity and adsorption capacity of activated bamboo charcoal before it becomes too saturated or full, influences its efficiency in filtering and reducing foul odors. So the longevity of the carbon device would last around 3 to 6 months depending on the pollutant levels and usage of the environment, but recommended to be maintained for 14 to 28 weeks, and closely observe if it is still filtering and reducing foul odors, replacing it with new activated bamboo carbon powder if its efficiency drops.

The overall understanding and gathered information we now can conclude that bamboo charcoal any type or Moso Bamboo is the best odor eliminating method that is already widely used to help minimize health risks from inhaling VOC compounds. To activate regular bamboo charcoal with the use of citric acid or lemon extract helps in transforming the bamboo charcoal's surface area more larger and wider pores for more molecule and particle odors to be encapsulated and filtered out. These open pores are what give activated carbon its strong adsorption ability the more open pores, the more odors and pollutants it can trap.

Mohamed et al. (2024) concluded that Activated carbon consists of a wide range of carbonized materials that are characterized by high porosity and large surface area, meaning the adsorption of activated charcoal removing odor-producing gases and particles from the air by leading to them to attach on its porous surface area. Because of its strong adsorption capacity, it has been found to be highly effective in getting rid of unpleasant scents in confined spaces. It is a common choice for natural air purification because of its chemical and physical structure, which enables it to capture and filter out odor-causing chemicals.

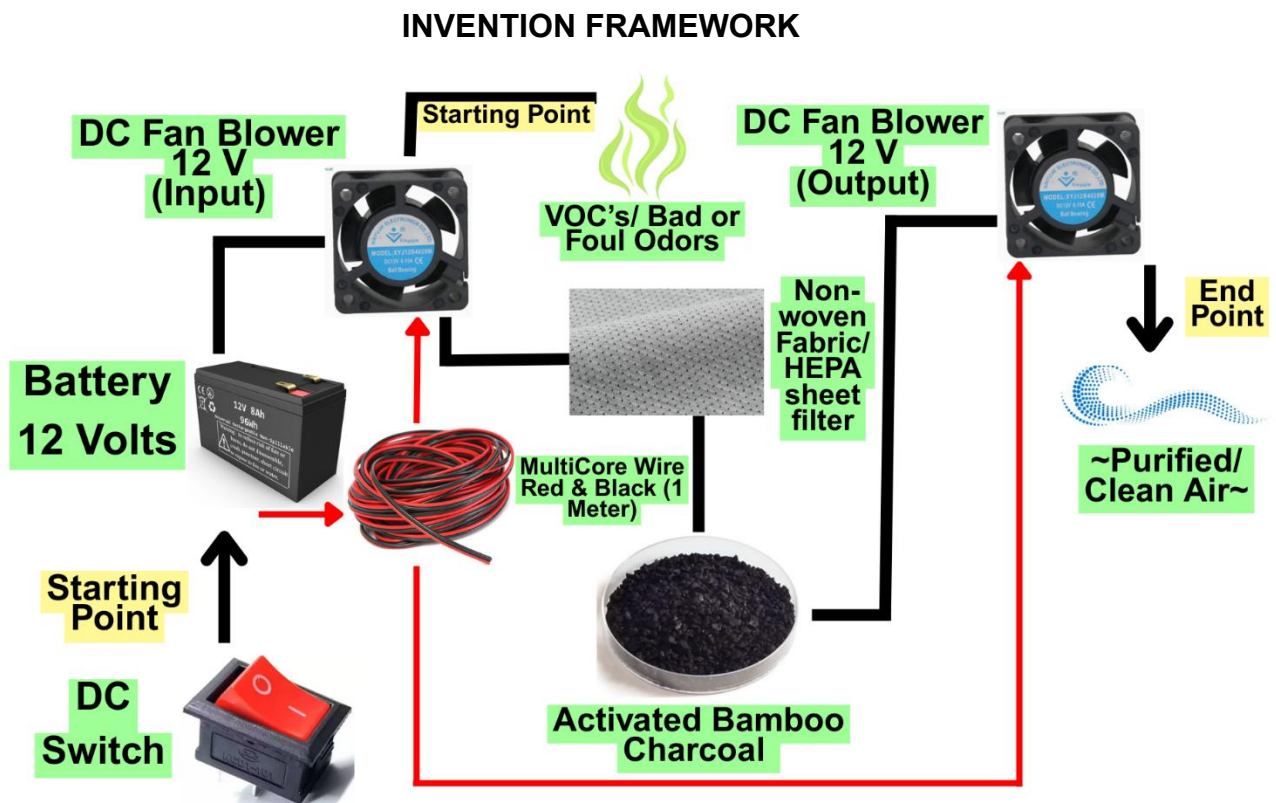

Figure 1. Inner components of the AC-BaC Device Diagram.

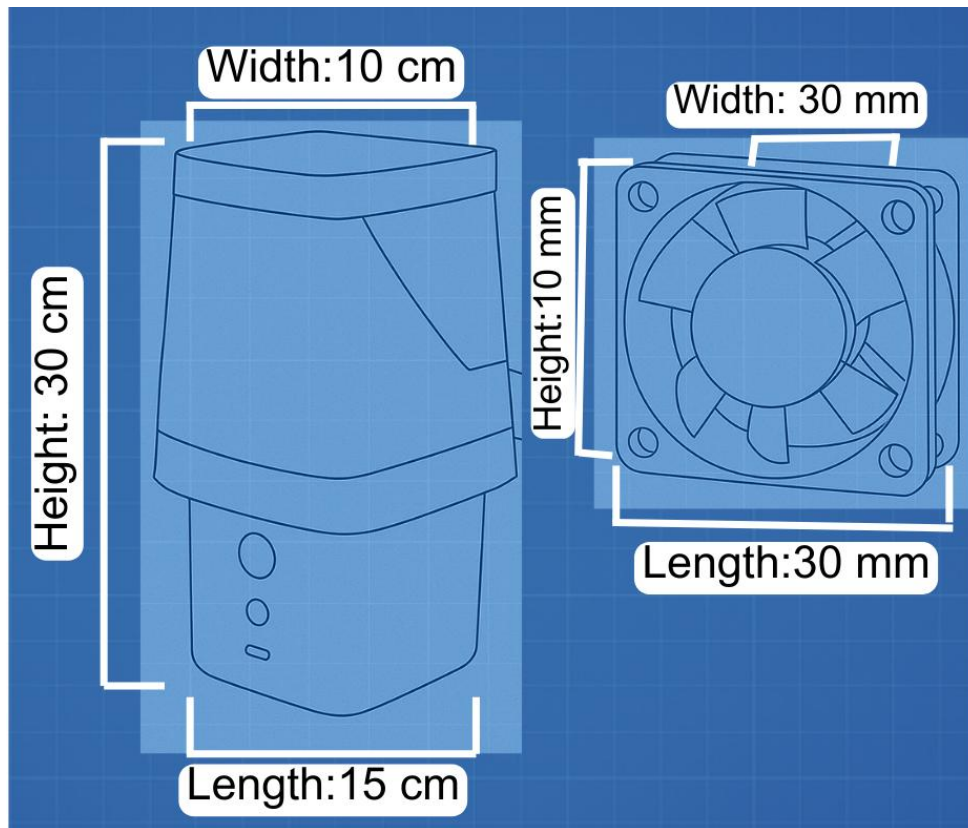

Figure 2. Bamboo Activated Charcoal Air Purification Device Blueprint w/ Dimensions.

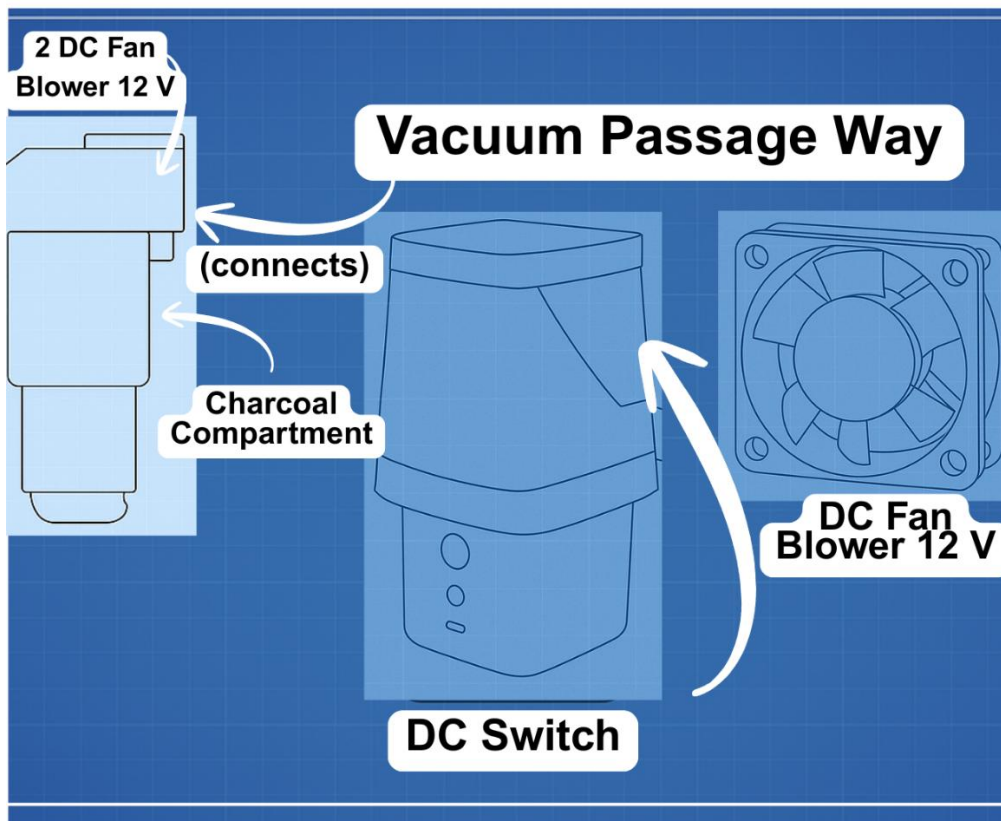

Figure 3. Bamboo Activated Charcoal Air Purification Device Blueprint w/ labels.

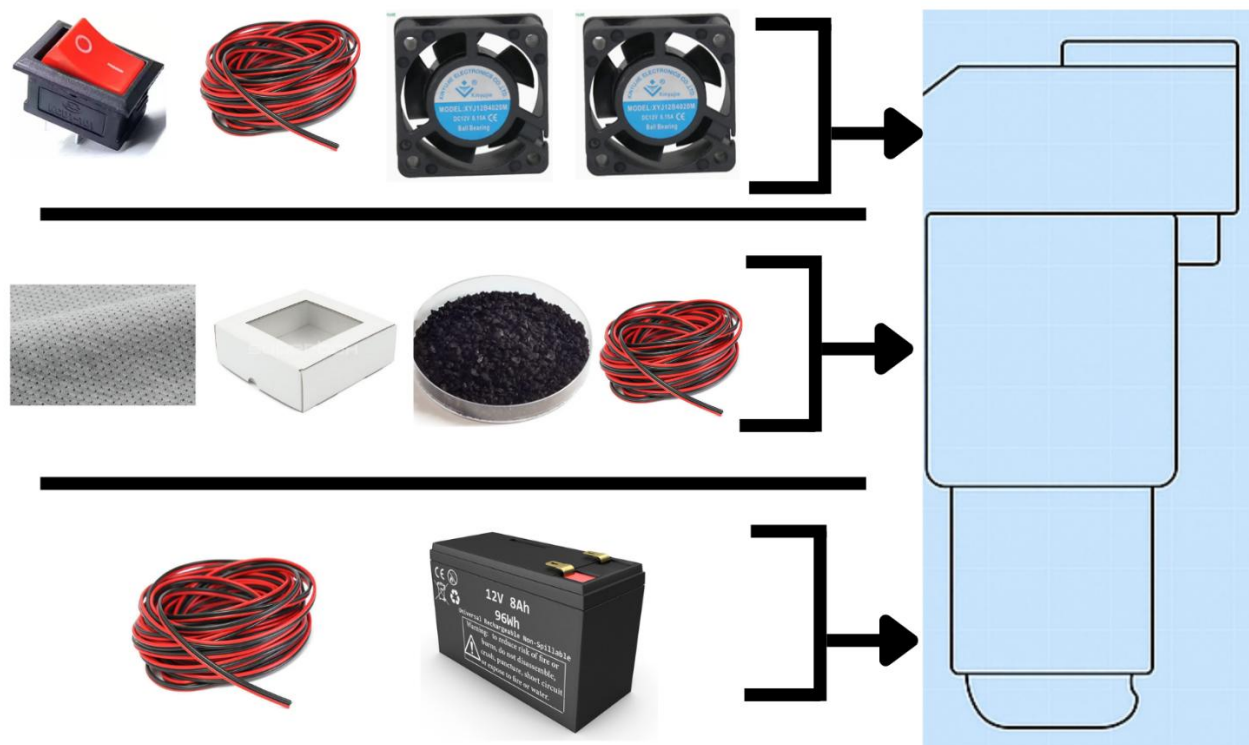

Figure 4. The components and their designated locations inside the AC-BaC Vacuum Device.

MATERIALS & METHODS

Materials

I. Making the Activated Bamboo Charcoal (Needed materials):

MATERIALS	QUANTITY
Bamboo (raw, for making charcoal)	1 kg
Water	90 ml (Depends)
Clean Bottle/ Jar with lid	1 pc.
Mortar and Pestle (optional) or Safety Working Gloves	1 set
Lemon Juice	30 ml (half a lemon) (Depends)
Sieve	1 pc. (stainless)
Other materials: Plastic Container and regular spoon, Knife and cutting board, Measuring Cups and Clean Basin	1 set

II. Making the portable pack vacuum for the AC-BaC device (Needed materials):

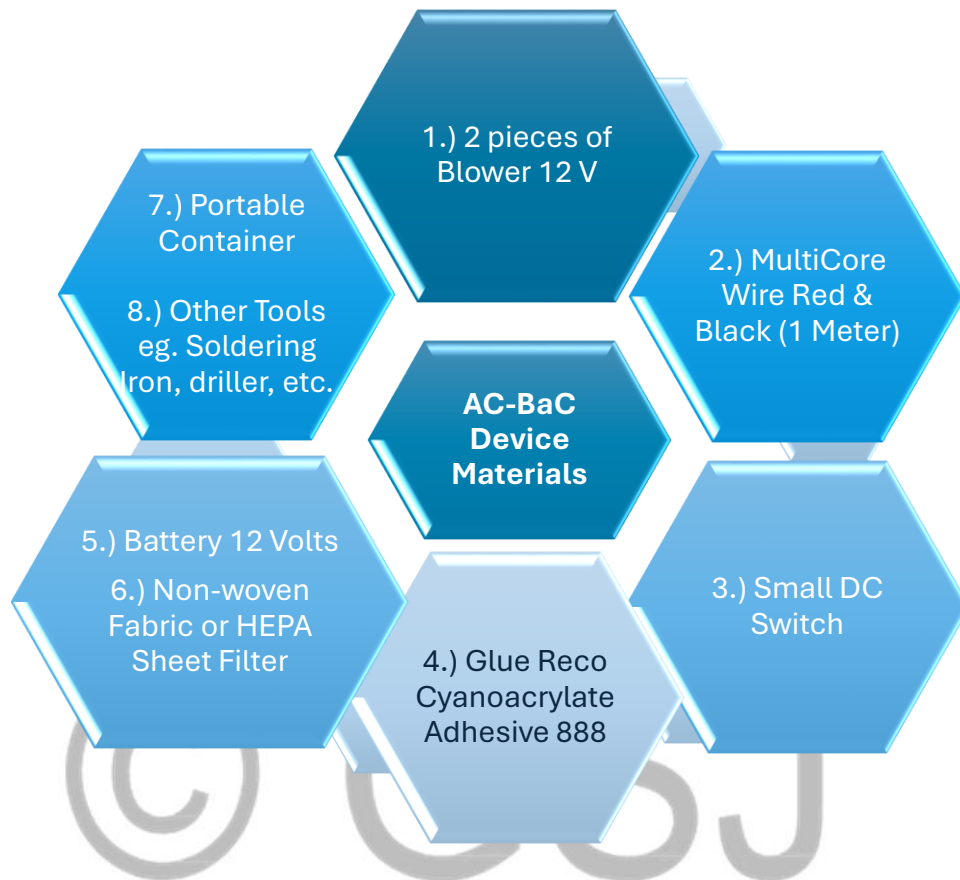

Methods

I. Phase 1: Bamboo Charcoal Production

Phase 1.1: Gather and find Moso Bamboo



Phase 1.2: Cut the Moso Bamboo into pieces (with adult supervision help)



Phase 1.3: Create a fire pit below the ground in an available and free space area.



Phase 1.4: Cook the chopped pieces of the Moso Bamboo for over 3-5 hours with constant supervision.

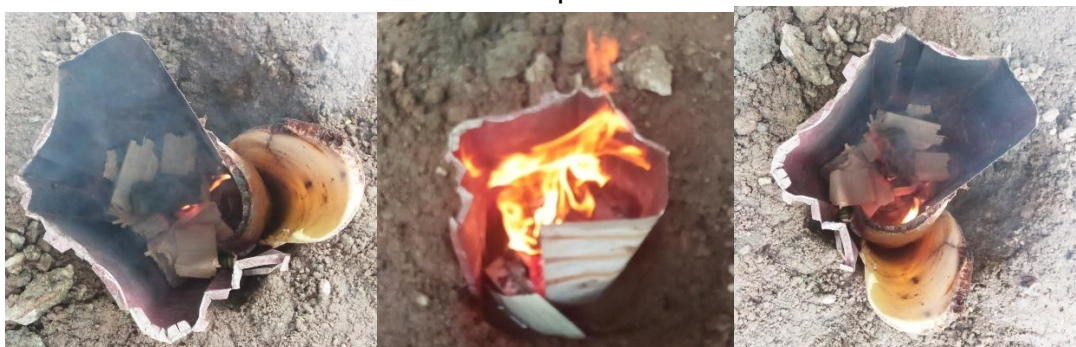

Phase 1.5: Put out the fire then take out the now freshly made bamboo charcoal and let them cool down and air dry.



Credits to the one who helped in attaining the Moso Bamboo: Mr. Richard Gildore

II. Phase 2: Activation of Bamboo Charcoal

Phase 2.1: Gather materials (e.g Lemon, water, clean container, measuring cup, etc.)

Phase 2.2: Make the Lemon solution, Cut a lemon in half for 30 ml of Lemon juice then pour it in the clean container, after that pour in 90 ml of water. (**Note: The proportion or ratio of the Lemon Solution should be 1/3, depending the desired amount of Lemon Solution.**)





Phase 2.3: Take a decent amount of Bamboo Charcoal then put them inside the clean basin then wash the Bamboo Charcoal thoroughly to remove ashes then dry them afterwards.



Phase 2.4: Crushing the bamboo charcoal (**Note: Optional to use Mortar and Pestle but recommended to use hands with safety working gloves in crushing the dried bamboo charcoal to ensure not to over grind or over crush the charcoal.**)



Phase 2.5: Transfer crushed bamboo charcoal to a clean bottle while also pouring and adding the lemon mixture one spoon at a time, repeat the process and then mix.



Phase 2.6: After mixing the bamboo charcoal and lemon solution, seal the bottle with its lid then let it settle down for 24 hours.

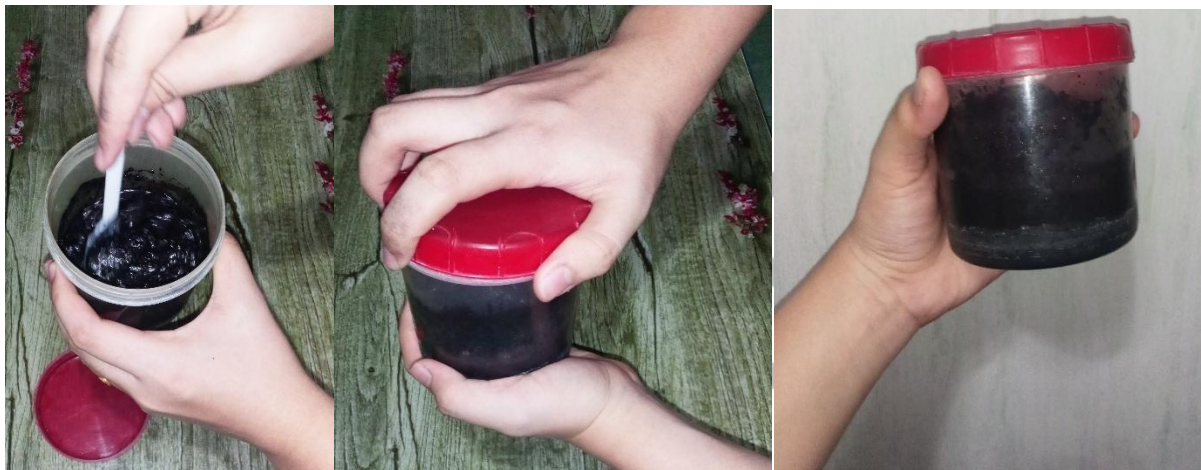

Phase 2.7: After 24 hours, strain the soaked charcoal using a sieve. Then wash and rinse thoroughly afterwards.



Phase 2.8: After removing the excess water, now cook the bamboo charcoal on a stove or any other heat platforms. Heat until bamboo charcoal is completely dry.



Phase 2.9: When the bamboo charcoal is now fully dried, transfer to a clean container and let it cool off. The Bamboo Charcoal is now activated.



III. Phase 3: Making and assembling the Vacuum Device (Researcher required help and guidance from a Technician/ Professional.)

Phase 3.1: Collect and gather materials.



Phase 3.2: Carve two holes on each side of the chosen portable container for input and output of the vacuum.

Phase 3.3: Attach the 2 DC fan blowers using the glue adhesive 888, make sure it aligns to each of the carved holes, and connect its wires using the 1m wire to the 12 volts battery.

Phase 3.4: Place the battery at the bottom of the container and ensure its placement, then arrange the wires for a neat wiring system.

Phase 3.5: Add the small DC switch to the wiring system to connect both DC fan blowers, afterwards attach it to the side.

Phase 3.6: Make a custom container for the activated bamboo charcoal, an enclosure that will ensure its placement inside the vacuum device. Using a non-woven fabric or HEPA sheet filter (optional) as the lid of the container.

Phase 3.7: Make finishing touches, ensure the wires, container, the battery and DC fans are stable in place before putting and adding the activated bamboo charcoal inside its own custom container. Then close the portable container after.

Phase 3.8: Conduct tests and trials to check for any errors or malfunctions of the device.

Credits to the experienced technician who helped build the project:

Mr. Elmar R. Espineta

Overall amount of the AC-BaC Vacuum Device

ITEMS	PRICE
Bamboo	₱100
Lemons	₱125
2 pcs. DC Fan Blower 12 V	₱110
MultiCore Wire Red & Black (1 Meter)	₱15
Small DC Switch	₱10
Glue Reco Cyanoacrylate Adhesive 888	₱110
Battery 12 Volts	₱495
Plastic casing/ Portable Container	₱969
Non-woven fabric / HEPA sheet	₱80
TOTAL PROJECT COST:	₱2014

IV. Phase 4: Testing and Trial

After the assembly and creation of the AC-BaC Vacuum Device, conducted multiple tests and trials to ensure that the vacuums are functioning, to guarantee that the input and output airflow is operating smoothly and efficiently taking in the foul odors and filtering them out. The research had one trial per day. Exactly monitoring its performance activity, conducted inside a large plastic container that will emit smoke that represents as the foul odor smell. Trial for one week or 7 days is necessary to test the AC-BaC's device consistency and efficacy in performance and capability, to also observe its accuracy and authenticity in reducing bad odors.

The functionality test is aimed to check if all of the components in the device is functioning and operating correctly, this includes the 12V battery supply if it will support and charge the 2 DC Fans that serves as the input and output airflow of the vacuum, and the DC switch if it is successfully connected in wiring as a one click power source for the overall device.

RESULTS

Accuracy and Consistency of AC-Bac Vacuum Device in filtering out foul odors

The table below illustrates the overall view of the accuracy and consistency test results based on the measurable, numerical or quantitative data gathered from using the tool, the Air Quality Meter. Having the unit of pm2.5 that measures fine particulate matter with a diameter of 2.5 micrometers or smaller, which can include dust, soot, smoke, and other tiny particles, extremely small objects like atoms and molecules.

Comparing the odor, the experiment makes use of smoke that acts or represents as the foul bad odors or the smell. Users are gonna smell how the AC-BaC device works but we need to see and know how much the AC-BaC device can filter out, before and after using inside the enclosed area, it will be an important part of concluding if the activated bamboo carbon is effective in filtering and reducing foul odors. Assessing, if the air quality meter shows a large value before using the device and then if the value decreases after utilizing the device then it can be concluded that the goal of the study is obtained and its odor filtering process is effective.

Table #1. Monitoring of Each Trial

Day	Baseline VOC/ Air Quality Before AC-BaC (pm2.5)	Air Quality After using AC-BaC Device(pm2.5)	% Reduction
1	999	011	98.9%
2	999	005	99.5%
3	999	010	99%
4	999	008	99.2%
5	999	013	98.7%
6	999	006	99.4%
7	999	007	99.3%

Formula for Percentage Reduction: *To know how much the reduction rate before and after utilizing the device.*

$$\text{Percent Reduction} = \frac{(\text{Baseline VOC} - \text{After AC-BaC Air Quality})}{\text{Baseline VOC}} \times 100$$

Monitored Air Quality based on the Performance Activity of the AC-BaC Device

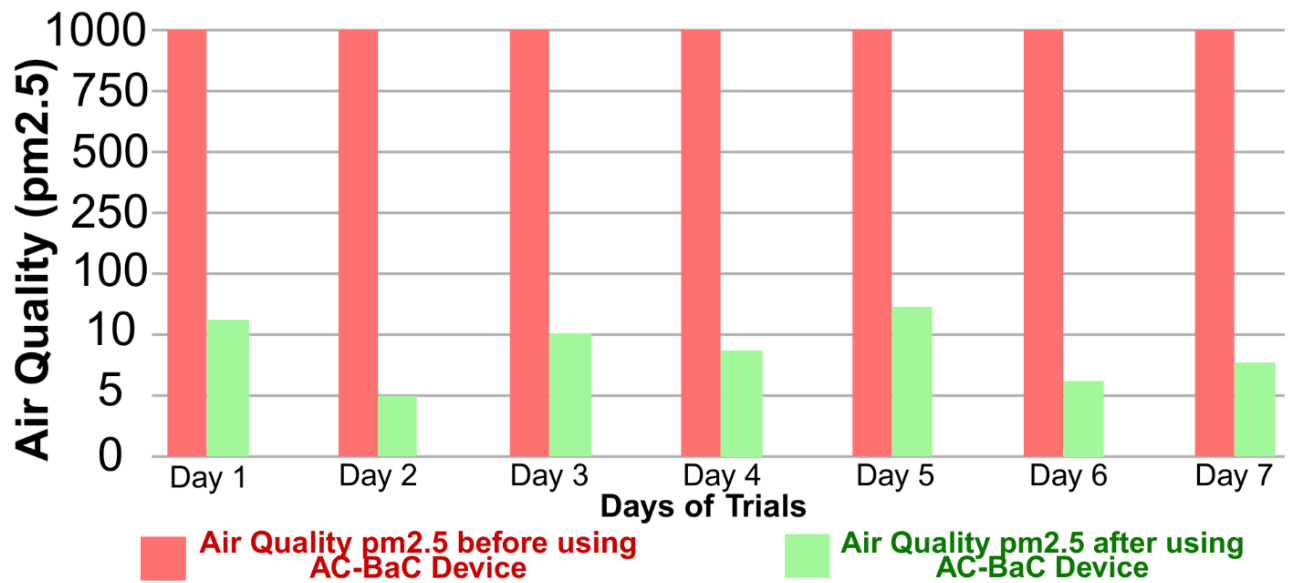

Bar Graph Visual of Comparing the Quality of Air before and after using the Device

FUNCTIONALITY TEST

The table below shows the results of the functionality tests performed for all system components used. Almost all of the components had no severe errors and the device has been operating smoothly.

Table #2. Functionality of Each Component.

Components	Test Description	Expected Outcome	Actual Outcome	Severity of Errors
12V Battery	Testing the power supply to ensure it provides the enough and the right amount of voltage to power the vacuum.	The power supply will provide 12V as required to operate the fans.	The power supply provides 12V as required to operate the fans.	None
DC Switch	Toggling the switch on and off	The vacuum device will turn on and off succesfully.	The vacuum device turns on and off.	None
2 DC Blower/ Vacuum Fans (Input and Output)	Powering the device off and on then observe its airflow	The airflow of the input fan will take in air while the output fan would emit out air.	The airflow of the input fan takes in air while the output fan emits out air.	None

DISCUSSION

CONSISTENCY

The researcher made several observations based on the monitored data collected from over the trials for one week. The calculated percentage reduction of bad odors represented by smoke were steady and consistent in value range, indicating that the AC-BaC Device is reliable in filtering out foul odors. The results of the device varied each day but maintained the consistency of its performance activity reduction percentage.

For each day measurement trial of using the Air Quality Meter, it consistently showed results of a large numerical value before using the device and then the value decreases right after utilizing the device concluding that the odor filtering process by the activated bamboo charcoal is working, successful and accurate.

VARIATION BETWEEN REPEATED OBSERVATIONS/ TRIALS

- The readings varied slightly across trials due to environmental and human factors, but the general trend showed a consistent reduction of around 98–99% VOC levels.
- Standard deviation of ~3–5 pm_{2.5} indicated relatively stable performance.

EFFECT OF UNCONTROLLED EVENTS EXPECTED WHEN UTILIZING THE DEVICE

- Open windows/doors allowed external air to enter, making some trials register higher baseline levels.
- Inconsistent or varied room activity (e.g., someone moving or using perfume/chemicals nearby, the frequency use of bathroom) caused occasional spikes in data.

IMPROVEMENTS FOR FUTURE STUDIES

- Would conduct the experiment in a sealed room with minimal human activity to reduce external factors.
- When gathering data from conducting experiments and trials of the AC-BaC Device, would use more tools next time such as Air Quality Monitor with TVOC and Formaldehyde Sensors, and Gas Sensors.
- Increase the number of trials for stronger statistical confidence and basis for authenticity and reliability.

FURTHER EXPERIMENTATIONS IF GIVEN THE CHANCE

1. **Long-term Testing** – Measure how long the bamboo charcoal remains effective before saturation.
2. **Comparative Analysis** – Directly test against commercial air fresheners and chemical purifiers.
3. **Test different Bamboo Species or other more carbonaceous materials** – Compare Moso bamboo with other types to see which yields the best adsorption.
4. **Humidity/Temperature Effects** – Test how environmental changes affect adsorption efficiency.
5. **Scaling Up** – Try conducting trials in a more larger and wider areas (eg. Classrooms, Bedrooms, Work office, etc.) to measure its scope range.

FUNCTIONALITY

The AC-BaC device is designed to simply function as a portable air purification system that utilizes activated carbon derived from Moso bamboo charcoal. Its primary mechanism involves drawing in foul odors into the device through a fan-driven vacuum process, passing it through a compartment containing activated bamboo charcoal granules. Due to its high surface area and porous structure, the activated bamboo charcoal adsorbs volatile organic compounds (VOCs) and odor-causing molecules, which is the natural filtering process, then it expels out the filtered air through the vacuum's output fan, thereby improving indoor air quality.

This functionality shows the potential and ability of bamboo-based activated carbon as an environmentally sustainable alternative to synthetic filters and chemical-based air fresheners.

FEASIBILITY

The project is supported by its availability, affordability, environment- friendly and sustainability of its materials. Bamboo, the primary raw material for activated carbon production, is abundant, renewable, cost-effective and doesn't promote or use any type of add-on chemicals to filter out odors. The device itself requires only common components such as a 2 DC Blower Fans that acts as the vacuum's input and output, a rechargeable 12V Battery Supply, and simple pack portable custom casing, all of which are accessible in local markets.

While minor technical expertise and guidance is necessary for wiring and assembly, the overall construction is achievable with modest resources. Furthermore, the device's low energy consumption and portability make it practical for real-world applications in households and other confined indoor spaces or areas.

SCOPE AND LIMITATIONS

Testing in larger areas, a wider scope and other odor sources that charcoal alone might not be able to completely eliminate and filter out may cause limitations and obstacles for the study. Observation logs will be conducted to note down any changes in odor filtering over time, monitoring environmental conditions such as the air humidity, temperature and etc. to see if it'll affect the Activated Carbon's filtering process, efficacy and effectiveness.

Additionally, the study is limited to confined indoor environments and short-term experimental trials. It does not account for long-term performance, large-scale applications, or the adsorption efficiency of bamboo charcoal against all possible pollutants. The study also focuses solely on Moso bamboo as the activated carbon source, therefore excluding any more potential comparisons with other bamboo types or carbonaceous materials.

BENEFITS

This project will help improve indoor air quality, it is environment and user friendly as it does not make use of any chemicals and it's not complicated for users to manage. It will also help households or those who struggle with foul odors by using this device. Additionally, it helps the community reduce air pollution and bad odor problems. Moreover, it helps by:

Environmental Sustainability. This study promotes the use of bamboo, a renewable, abundant and fast-growing resource, as an eco-friendly alternative, natural filtering process instead of using chemical-based air purifiers.

Cost-Effectiveness and Availability. The device utilizes readily available and affordable materials such as bamboo, simple electronic components, and recyclable casing that can be found in markets, making it a low-cost alternative to commercially available air purifiers.

Health and Safety Improvement. By adsorbing and filtering volatile organic compounds (VOCs), foul odors, and air pollutants, the device contributes to better indoor air quality, reducing possible health risks associated with poor ventilation and chemical-based air fresheners.

Innovation and Practical Application. The AC-BaC device uses bamboo charcoal technology with modern engineering design, showcasing an innovative approach to air purification that is both functional, portable and environment- friendly.

Commercial and Market Potential. The study focuses on developing a low-cost, sustainable air purifier that has the potential to be marketed to households, schools, offices, and communities, particularly in areas with limited access to advanced purification systems and poor ventilation.

Educational Contribution. This research offers valuable insights into the science of adsorption, sustainable engineering, and applied environmental solutions, serving as a useful reference or inspiration for future academic and community-based projects.

Community and Society Impact. Through its affordability and accessibility, the device has the potential to benefit low-income households and confined poor ventilation communities by providing an alternative to expensive air purifiers, thereby improving public health and quality of life.

CONCLUSIONS

This study demonstrated and introduced the potential of Activated Carbon Bamboo Charcoal (AC-BaC) as a sustainable, affordable, and effective material for reducing and filtering foul odors and volatile organic compounds (VOCs) in confined spaces and also supporting a safer environment for individuals, especially those with asthma or respiratory sensitivities, by reducing exposure and presence of contaminated air.

Using Moso bamboo, activated with citric acid (lemon solution) and combined into an innovative vacuum-powered device, the project proved that AC-BaC can improve indoor air quality while offering an eco-friendly alternative to chemical-based air fresheners. Despite minor limitations such as the finite lifespan of activated carbon and possible errors in air quality measurement, the results confirm the feasibility, functionality, and marketability of the device.

Overall, this study provides both a scientific and practical contribution by presenting a renewable, low-cost, and efficient solution that addresses environmental concerns, reducing air pollution and promotes healthier and comfortable living spaces, an innovation that helps trap harmful particles, odors, and pollutants that can affect people's health. It is especially beneficial for those with asthma, allergies, and respiratory problems, as it helps lessen irritants in confined spaces. Overall, this innovation promotes healthier breathing, safer living environments, and contribute to reducing smell/ air pollution.

ACKNOWLEDGEMENTS

The researcher would like to express their heartfelt gratitude to everyone who has contributed to the completion and success of this study, "AC-BaC: Effectiveness of Utilizing Activated Carbon Moso Bamboo Charcoal with an Innovation of a Vacuum Device on Reducing Foul Odors in Confined Spaces."

First and foremost, the researcher sincerely thanks their Research Adviser, Ms. JC May Fernandez, for their invaluable guidance, constant encouragement, and constructive feedback that greatly helped in improving this study.

The researcher also extends their gratitude to their guardian parent, Mrs. Miraluna Gildore, for their unwavering support, understanding, and encouragement throughout the entire process of completing this research.

The researcher gives a special thanks to Mr. Elmar R. Espineta the experienced expert technician who helped build, construct, design and assemble the AC-BaC Device. For their time, help, effort, and insightful comments that enhanced the quality and depth of this research, making the project possible and come to life, thank you so much.

The researcher is also thankful to Mr. Richard Gildore who provided the Moso Bamboo Resource, contributing to the progress and data for the study's success.

This study would not have been possible without the collective efforts, cooperation, and guidance of all those mentioned above.

FUTURE DEVELOPMENT

The future development of this innovation aims to enhance its functionality and adaptability within specific areas and components:

1. Making minor adjustments of the design and internal structure of the AC-BaC device for optimizing airflow systems and increasing the adsorption lifespan of activated bamboo charcoal.
2. The integration of smart sensor for automatic odor detection and fan activation, making the device more user-friendly and energy-efficient.
3. Additionally, scaling and widening the scope of the device for larger indoor spaces or industrial applications could broaden its market potential.
4. Further experiments can also test other natural activating agents or combinations of eco-friendly materials to strengthen its purification performance.

Overall, these advancements and adjustments would improve and make the AC-BaC device a more sustainable, efficient, and commercially appropriate for being an air purification solution. Some components requires development, the construction design and structure of the device container can have some refinement for better use and reliability.

REFERENCES

- Alves, A. T., Lasmar, D. J., de Andrade Miranda, I. P., da Silva Chaar, J., & dos Santos Reis, J. (2021). *The potential of activated carbon in the treatment of water for human consumption: A study of the state of the art and its techniques used for its development*. *Advances in Bioscience and Biotechnology*, 12(06), 143–153. <https://doi.org/10.4236/abb.2021.126010>
- Bhave, P. P., & Yeleswarap, D. (2020). Removal of indoor air pollutants using activated carbon—A review. *Veer mata Jijabai Technological Institute*. <https://www.researchgate.net/publication/335939798> Removal of Indoor Air Pollutants Using Activated Carbon-A Review
- Chuan-Chi Chien, Ying-Pin Huang, Wie-Chieh Wang, Jun-Hsing Chao, Yuan-Yao Wei (2011). Efficiency of Moso Bamboo Charcoal and Activated Carbon for Adsorbing Radioactive Iodine. *CLEAN – Soil, Air, Water*. <https://onlinelibrary.wiley.com/doi/abs/10.1002/clen.201000012>
- Dąbrowski, A. (2001). Adsorption—from theory to practice. *Advances in Colloid and Interface Science*, 93(1–3), 135–224. <https://www.sciencedirect.com/science/article/abs/pii/S0001868600000828>
- Distilled Spirits (2023). Activated carbon (AC) is a universal term for a type of adsorbing and absorbing substances of a crystalline form. <https://www.sciencedirect.com/topics/agricultural-and-biological-sciences/activated-carbon>
- Dubinin, M. M. (1989). Fundamentals of the theory of adsorption in micropores of carbon adsorbents: Characteristics of their adsorption properties and microporous structures. *Carbon*, 27(3), 457–467. <https://www.sciencedirect.com/science/article/pii/000862238990078X>
- J.Paul Chen, Shunnian Wu, Kai-Hau Chong (2003). Surface modification of a granular activated carbon by citric acid for enhancement of copper adsorption. *Carbon*. [https://doi.org/10.1016/S0008-6223\(03\)00197-0](https://doi.org/10.1016/S0008-6223(03)00197-0)
- Kamna Chaturvedi and others. (2023). Bamboo for producing charcoal and biochar for versatile applications. <https://www.researchgate.net/publication/366580545> Bamboo for producing charcoal and biochar for versatile applications
- Kurt Spokas, Nikolas Hagemann, Hans-Peter Schmidt and others (2018). Activated Carbon, Biochar and Charcoal: Linkages and Synergies across Pyrogenic Carbon's ABCs. *Water* (2018),10(2), 182; <https://doi.org/10.3390/w10020182>
- Lan, J., Ou, J., and others. (2023). [Title not provided]. *Journal of Industrial and Engineering Chemistry*. <https://www.sciencedirect.com/science/article/abs/pii/S1226086X22007596>
- Le-Minh, N., Sivret, E. C., Shammay, A., & Stuetz, R. M. (2018). Factors affecting the adsorption of gaseous environmental odors by activated carbon: A critical

review. *Critical Reviews in Environmental Science and Technology*.
<https://doi.org/10.1080/10643389.2018.1460984>

Reza, M. S., Yun, C. S., Afroze, S., Radenahmad, N., Abu Bakar, M. S., Saidur, R., Taweekun, J., & Azad, A. K. (2020). Preparation of activated carbon from biomass and its applications in water and gas purification: A review. *Arab Journal of Basic and Applied Sciences*, 27(1), 208–238.
<https://doi.org/10.1080/25765299.2020.1766799>

S.S.M. Isa*, M.M. Ramli, N.A.M.A. Hambali, S.R. Kasjoo, M.M. Isa, N.I.M. Nor, N. Khalid and N. Ahmad. (2016). Adsorption Properties and Potential Applications of Bamboo Charcoal: A Review. MATEC web conference, Volume 78, 2016.
https://www.mateconferences.org/articles/mateconf/abs/2016/41/mateconf_Icongdm2016_01097/mateconf_Icongdm2016_01097.html

Wang, Z., & Zhang, J. S. (2011). Characterization and performance evaluation of a full-scale activated carbon-based air filter used for VOC removal in building ventilation systems. *Building and Environment*, 46(3), 637–643.
<https://www.sciencedirect.com/science/article/abs/pii/S0360132310003008>

WikiHow, Co authored by Bess Ruff (2025). How to Make Activated Charcoal.

<https://www.wikihow.com/Make-Activated-Charcoal>

Yang, X., Zhong, H., Zhang, W., Liu, Y., Sun, N., Kuang, R., Wang, C., Zhan, A., Zhang, J., Tang, Q., Li, Z. (2023). Progress in Adsorptive Removal of Volatile Organic Compounds by Zeolites. *Aerosol Air Qual. Res.* 23, 220442.
<https://doi.org/10.4209/aaqr.220442>